

Nennspannung	V DC	24						205						V DC	Voltage rating
ED* LK	%	100	75	45	25	15	7	100	70	45	20	9	6	%	ED* LK
Nennstrom	A	0,80	0,96	1,55	2,45	3,90	9,20	0,08	0,12	0,18	0,35	0,77	1,18	A	Current rating
Nennwiderstand	Ω	30,0	25,0	15,5	9,8	6,2	2,6	2.600	1.735	1.148	592	268	174	Ω	Nominal resistance
E 52, 25°	MA Ncm	13,0	15,0	20,0	25,0	31,0	41,0	10,5	14,5	18,5	26,0	36,0	40,0	Ncm MA	E 52, 25°
	ME Ncm	18,5	21,5	26,0	30,0	34,0	41,0	16,5	21,0	25,0	31,0	37,0	40,5	Ncm ME	
E 53, 35°	MA Ncm	10,0	11,5	16,0	22,0	27,0	36,5	8,0	11,0	15,0	23,0	32,0	36,0	Ncm MA	E 53, 35°
	ME Ncm	18,0	19,5	23,5	27,0	29,0	31,0	15,5	19,0	22,0	27,5	30,5	31,0	Ncm ME	
E 54, 45°	MA Ncm	7,0	8,1	11,5	16,4	21,0	30,5	5,4	7,8	10,5	17,0	26,0	30,0	Ncm MA	E 54, 45°
	ME Ncm	15,6	17,2	20,8	23,0	25,5	27,5	13,3	16,6	20,0	24,0	27,0	27,0	Ncm ME	
E 56, 65°	MA Ncm	3,9	4,8	7,2	10,5	14,5	24,0	3,0	4,5	6,5	11,3	19,0	23,5	Ncm MA	E 56, 65°
	ME Ncm	14,5	15,7	18,5	21,0	22,0	22,5	12,3	15,0	18,0	21,3	22,5	22,5	Ncm ME	
E 59, 95°	MA Ncm	1,8	2,2	3,6	5,4	8,0	14,4	1,5	2,1	3,2	5,9	11,0	14,2	Ncm MA	E 59, 95°
	ME Ncm	12,7	13,7	15,2	16,1	16,5	15,0	11,3	13,4	14,8	16,3	16,0	15,0	Ncm ME	

* LK = Luftkühlung,
bei Kühlfläche ≥ 300 cm² ist die 1,7fache ED
zulässig

MA = Anfangsdrehmoment
ME = Enddrehmoment (5° vor Drehwinkelende)

Anschlussart: - Litze
- Steckhülsenanschluss
(6,3 DIN 46247)
Gewicht: ca. 570 g
Dyn. Trägheitsmoment
(Drehmasse): ca. 4,25·10⁻⁶ kg m²
Zeitkonstante: ca. 7–24 ms

Alle Magnete mit MA > 2,5 Ncm sind
mit Rückholfeder MR ca. 2,0 Ncm
lieferbar.

Die Betriebsspannung von 205 V DC
ergibt sich nach der Gleichrichtung von
230 V AC mittels Brückengleichrichter.

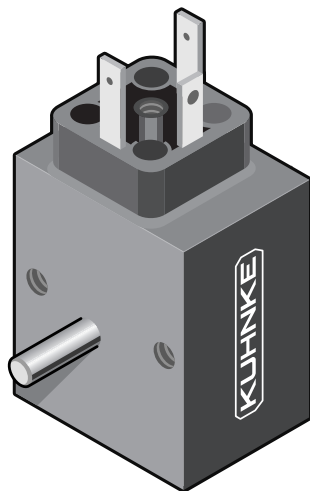

* By using a cooling surface ≥ 300 cm², the
permissible duty cycle can be extended up to
1.7x normal rating

MA = Initial torque
ME = End torque (5° before end of rotary angle)

Coil terminals: - Flying leads
- Terminal box
(6.3 DIN 46247)
Weight: appr. 570 g
Dyn. moment of
inertia (rotational
mass): appr. 4.25·10⁻⁶ kg m²
Time constant: appr. 7–24 ms

All solenoids with MA > 2.5 Ncm are
available with spring return, with a rating
of MR = 2.0 Ncm approximately.

The operational voltage of 205 V DC
results from rectifying 230 V AC with a
bridge rectifier.

