

Bistabiler Hubmagnet BI 8

Bistable Linear Solenoid BI 8

Stoßende und ziehende Ausführung

Thrust and pull type

Bestellformel	BI	8	- F -	24 V DC	15 % ED	Order specifications
Hubmagnet	BI					Linear solenoid
Bauart		8				Design type
Anschlussart						Coil terminals
Litze (Standardlänge 10 cm)			F			Flying leads (10 cm standard length)
Lötpins (Rastermaß)			L			Soldering pins (grid dimensions)
Nennspannung (Standardspannung) ¹⁾				24		Nominal voltage (standard voltage) ¹⁾
Zulässige relative Einschaltdauer bei Luftkühlung (LK)					15 % ED	Perm. duty cycle under air cooled conditions (LK)

¹⁾ Die Magnete sind auf Anfrage bis 30 V DC lieferbar

¹⁾ Other voltages are available on request up to 30 V DC

Gewicht:
Magnet: ca. 6 g
Anker: ca. 1,6 g
Standard:
Spannung: 24 V DC
Litze: 10 cm
Isolierstoffklasse: E (T_{grenz} = 120 °C)

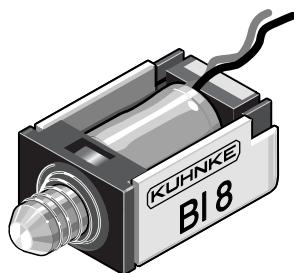

Weight:
Complete solenoid: appr. 6 g
Armature: appr. 1.6 g
Standard:
Voltage: 24 V DC
Flying leads: 10 cm
Insulation class: E (max. permissible temperature = 120 °C)

Isolationsgruppe nach: VDE 0110 C 75
Prüfspannung: 500 V (eff)
Schutzart: IP 00

Insulation group according to: VDE 0110 C 75
Test voltage: 500 V (eff)
Protection: IP 00

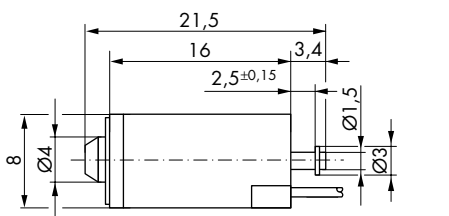
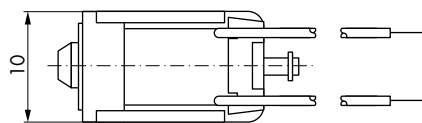

Maße im angezogenem Zustand

Hubrichtung

Dimensions given with armature in fully home position

Direction of stroke

Zul. rel. Einschaltdauer (ED)	%	15	% Perm. duty cycle (ED)
Nennaufnahme P _N	W	7,2	W Nominal coil power P _N
Anzugszeit (ED)	ms	12	ms Actuation time (ED)
Abfallzeit	ms	7	ms Drop-out time

Kraft-Weg-Diagramm F = f (s)

..... Federkraft
- - - - - Permanentkraft

Kraft bei waagerechter Bewegungsrichtung und bei 90 % Nennspannung und betriebswarmer Wicklung

Hub s = 0 entspricht dem angezogenen, bestromten Zustand

Kraft-Wege-Kennlinien sind ohne Feder gemessen

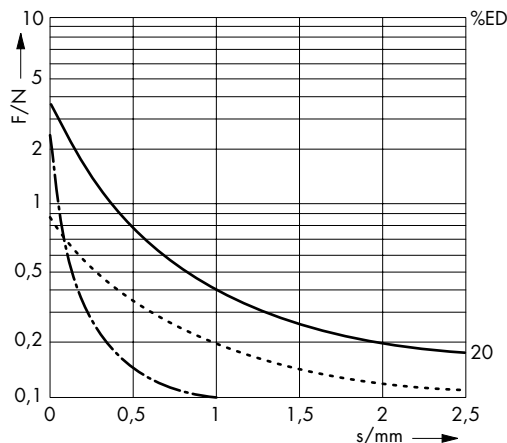

Force vs. Stroke diagramm F = f (s)

..... spring force
- - - - - permanent force

Force measured when operating in horizontal position, at 90 % rated voltage and with winding at operating temperature

stroke s = 0 corresponds to armature in fully home position

Force vs. stroke characteristics measured without return spring

Bistabiler Hubmagnet BI 13

Bistable Linear Solenoid BI 13

Stoßende und ziehende Ausführung

Thrust and pull type

Bestellformel	BI	13	- F -	24 V DC	25 % ED	Order specifications
Hubmagnet	BI					Linear solenoid
Bauart		13				Design type
Anschlussart						Coil terminals
Litze (Standardlänge 10 cm)			F			Flying leads (10 cm standard length)
Lötpins 0,63 (Rastermaß 8,9 mm)			L			Soldering pins 0.63 (grid dimensions 8.9 mm)
Nennspannung (Standardspannung) ¹⁾				24		Nominal voltage (standard voltage) ¹⁾
Zulässige relative Einschaltdauer bei Luftkühlung (LK)					25 % ED	Perm. duty cycle under air cooled conditions (LK)

¹⁾ Die Magnete sind auf Anfrage bis 30 V DC lieferbar

¹⁾ Other voltages are available on request up to 30 V DC

Gewicht:
Magnet: ca. 23 g
Anker: ca. 6 g
Standard:
Spannung: 24 V DC
Litze: 10 cm
Isolierstoffklasse: E (T_{grenz} = 120 °C)

Isolationsgruppe nach: VDE 0110 C 75
Prüfspannung: 500 V (eff)
Schutzart: IP 00

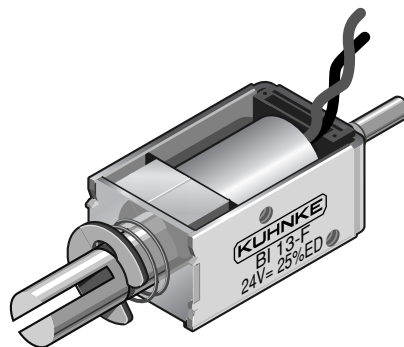

Weight:
Complete solenoid: appr. 23 g
Armature: appr. 6 g
Standard:
Voltage: 24 V DC
Flying leads: 10 cm
Insulation class: E (max. permissible temperature = 120 °C)

Insulation group according to: VDE 0110 C 75
Test voltage: 500 V (eff)
Protection: IP 00

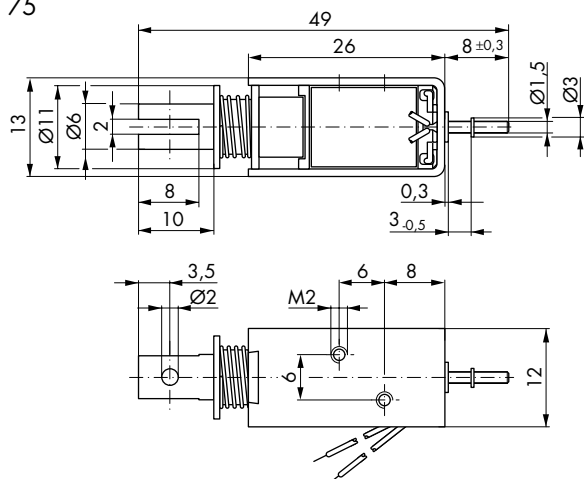

Maße im angezogenem Zustand

→
Hubrichtung

Dimensions given with armature in fully home position

→
Direction of stroke

Zul. rel. Einschaltdauer (ED)	%	25	%	Perm. duty cycle (ED)
Nennaufnahme P _n	W	7	W	Nominal coil power P _n
Anzugszeit (ED)	ms	14	ms	Actuation time (ED)
Abfallzeit	ms	12	ms	Drop-out time

Kraft-Weg-Diagramm F = f (s)

..... Federkraft
- - - - - Permanentkraft

Kraft bei waagerechter Bewegungsrichtung und bei 90 % Nennspannung und betriebswarmer Wicklung

Hub s = 0 entspricht dem angezogenen, bestromten Zustand

Kraft-Wege-Kennlinien sind ohne Feder gemessen

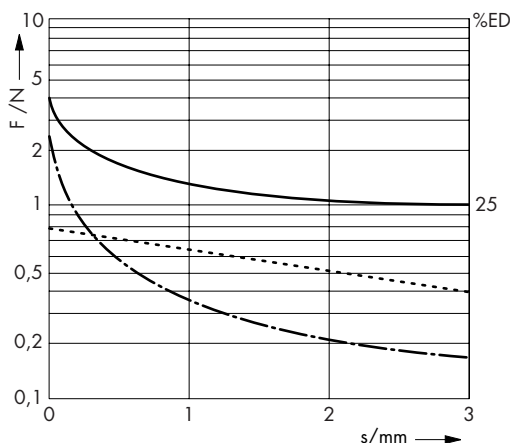

Force vs. Stroke diagramm F = f (s)

..... spring force
- - - - - permanent force

Force measured when operating in horizontal position, at 90 % rated voltage and with winding at operating temperature

stroke s = 0 corresponds to armature in fully home position

Force vs. stroke characteristics measured without return spring

Bistabiler Hubmagnet BI 17

Bistable Linear Solenoid BI 17

Stoßende und ziehende Ausführung

Thrust and pull type

Bestellformel	BI	17	- F -	24 V DC	25 % ED	Order specifications
Hubmagnet	BI					Linear solenoid
Bauart		17				Design type
Anschlussart						Coil terminals
Litze (Standardlänge 10 cm)			F			Flying leads (10 cm standard length)
Nennspannung (Standardspannung) ¹⁾				24		Nominal voltage (standard voltage) ¹⁾
Zulässige relative Einschaltdauer bei Luftkühlung (LK)					25 % ED	Perm. duty cycle under air cooled conditions (LK)

¹⁾ Die Magnete sind auf Anfrage bis 60 V DC lieferbar

¹⁾ Other voltages are available on request up to 60 V DC

Gewicht:
 Magnet: ca. 46 g
 Anker: ca. 12 g
 Standard:
 Spannung: 24 V DC
 Litze: 10 cm
 Isolierstoffklasse: E ($T_{\text{grenz}} = 120\text{ °C}$)
 Isolationsgruppe nach: VDE 0110 C 75
 Prüfspannung: 800 V (eff)
 Schutzart: IP 00

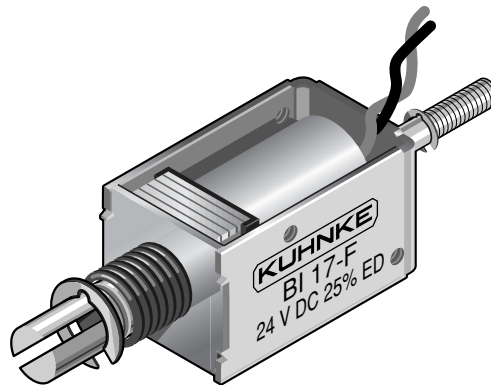

Weight:
 Complete solenoid: appr. 46 g
 Armature: appr. 12 g
 Standard:
 Voltage: 24 V DC
 Flying leads: 10 cm
 Insulation class: E (max. permissible temperature = 120 °C)
 Insulation group according to: VDE 0110 C 75
 Test voltage: 800 V (eff)
 Protection: IP 00

Zul. rel. Einschaltdauer (ED)	%	25	%	Perm. duty cycle (ED)
Nennaufnahme P_N	W	9,5	W	Nominal coil power P_N
Anzugszeit (ED)	ms	22	ms	Actuation time (ED)
Abfallzeit	ms	11	ms	Drop-out time

Kraft-Weg-Diagramm $F = f(s)$

..... Federkraft
 - - - - - Permanentkraft

Kraft bei waagerechter Bewegungsrichtung und bei 90 % Nennspannung und betriebswarmer Wicklung

Hub $s = 0$ entspricht dem angezogenen, bestromten Zustand

Kraft-Wege-Kennlinien sind ohne Feder gemessen

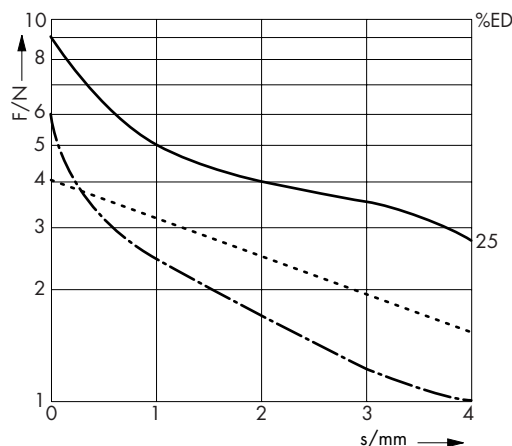

Force vs. Stroke diagramm $F = f(s)$

..... spring force
 - - - - - permanent force

Force measured when operating in horizontal position, at 90 % rated voltage and with winding at operating temperature

stroke $s = 0$ corresponds to armature in fully home position

Force vs. stroke characteristics measured without return spring

Bistabiler Hubmagnet
BI 17

Bistable Linear Solenoid
BI 17

Stoßende und ziehende Ausführung

Thrust and pull type

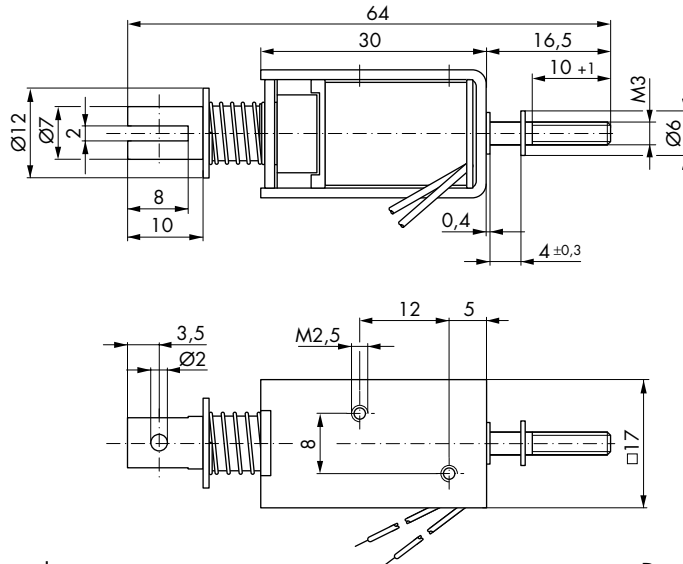

Maße im angezogenem Zustand

→
Hubrichtung

Dimensions given with armature
in fully home position

→
Direction of stroke

Bistabiler Hubmagnet BI 34

Bistable Linear Solenoid BI 34

Stoßende und ziehende Ausführung

Thrust and pull type

Bestellformel	BI	34	- F -	24 V DC	25 % ED	Order specifications
Hubmagnet	BI					Linear solenoid
Bauart		34				Design type
Anschlussart						Coil terminals
Litze (Standardlänge 10 cm)			F			Flying leads (10 cm standard length)
Nennspannung (Standardspannung) ¹⁾				24		Nominal voltage (standard voltage) ¹⁾
Zulässige relative Einschaltdauer bei Luftkühlung (LK)					25 % ED	Perm. duty cycle under air cooled conditions (LK)

¹⁾ Die Magnete sind auf Anfrage bis 60 V DC lieferbar

¹⁾ Other voltages are available on request up to 60 V DC

Gewicht:
Magnet: 220 g

Anker: 58 g
Standard:
Spannung: 24 V DC
Litze: 10 cm
Isolierstoffklasse: B ($T_{\text{grenz}} = 130\text{ °C}$)

Isolationsgruppe: 1,5 KV /3
Prüfspannung: 2500 V (eff)

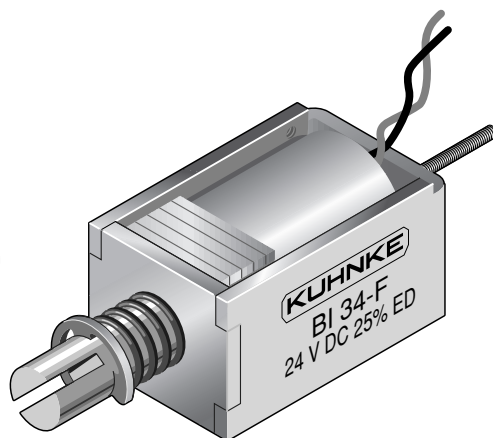

Weight:
Complete solenoid: 220 g
Armature: 58 g
Standard:
Voltage: 24 V DC
Flying leads: 10 cm
Insulation class: B (max. permissible temperature = 130 °C)
Insulation group: 1.5 KV /3
Test voltage: 2500 V (eff)

Zul. rel. Einschaltdauer (ED)	%	25	%	Perm. duty cycle (ED)
Nennaufnahme P_N	W	38	W	Nominal coil power P_N

Kraft-Weg-Diagramm $F = f(s)$

..... Federkraft
- · - · - Permanentkraft

Kraft bei waagerechter Bewegungsrichtung und bei 90 % Nennspannung und betriebswarmer Wicklung

Hub $s = 0$ entspricht dem angezogenen, bestromten Zustand

Kraft-Wege-Kennlinien sind ohne Feder gemessen

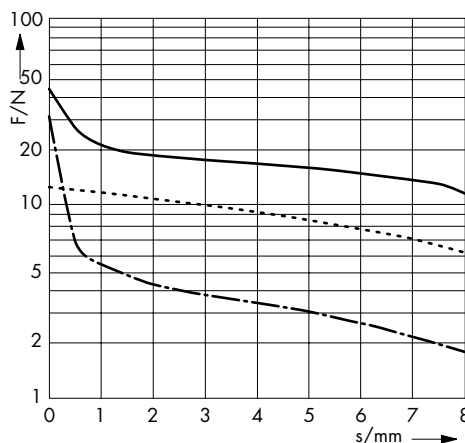

Force vs. Stroke diagramm $F = f(s)$

..... spring force
- · - · - permanent force

Force measured when operating in horizontal position, at 90 % rated voltage and with winding at operating temperature

stroke $s = 0$ corresponds to armature in fully home position

Force vs. stroke characteristics measured without return spring

Bistabiler Hubmagnet
BI 34

Bistable Linear Solenoid
BI 34

Stoßende und ziehende Ausführung

Thrust and pull type

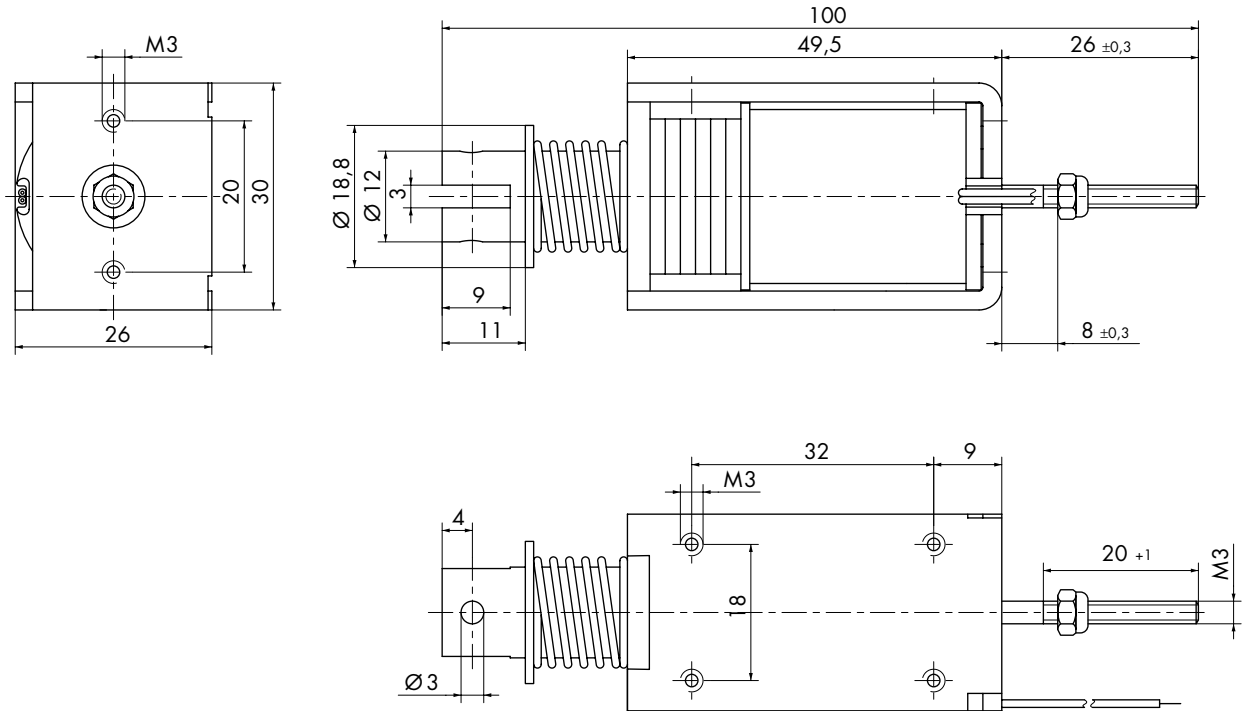

Maße im angezogenem Zustand

→
Hubrichtung

Dimensions given with armature
in fully home position

→
Direction of stroke